



Halo / 10 Watt LED Down Light

# cleanray™, the light ahead.

cleanray™ LED lights emit negligible Infra Red or Ultra Violet radiations, which are hazardous to health, in comparison with CFLs or fluorescent lamps.

## Product Description

The cleanray™ 10 watt LED down lights are energy efficient fittings, which can be ceiling mounted or surface mounted on POP (Plaster of Paris). These lights are made out of polycarbonate, a drop proof substance, with excellent electrical and mechanical properties. The fittings are built with high performance aluminum reflectors and acrylic diffusers to ensure enhanced and uniform light dispersion.

## Mechanical Data

The cleanray™ 10 watt LED down light weighs approximately 500 grams and uses an acrylic diffuser for enhanced light diffusion

Electrical Data		Optical Data	
Fixture Output	900 Lumens Initial	Wattage	10 Watts
Luminous Flux	> 90 Lm / Watt	Input Voltage	240 V AC, 50Hz
CRI	> 75	Driver Type	Constant Voltage Type
Color	5000 - 5700 Kelvin	Power Factor / Harmonics	0.8 / <15%

Note: The specifications are subject to change without prior notice.

Vignani Solutions Pvt. Ltd. 93/A, 4th B cross, 5th Block, Koramanagala Industrial Area, Bangalore 560095  
Telephone +91 80 4200 4212 | Fax: +91 80 4200 4260 / email: info@cleanray.in / www.cleanray.in

All cleanray products, patent pending technologies and brandnames are intellectual properties of vignani solutions. all rights reserved.

# Technical Specifications



## Halo / 10 Watt LED Down Light

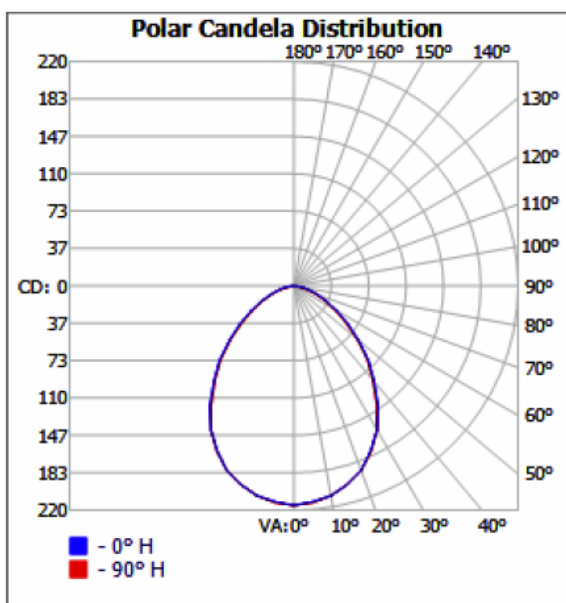
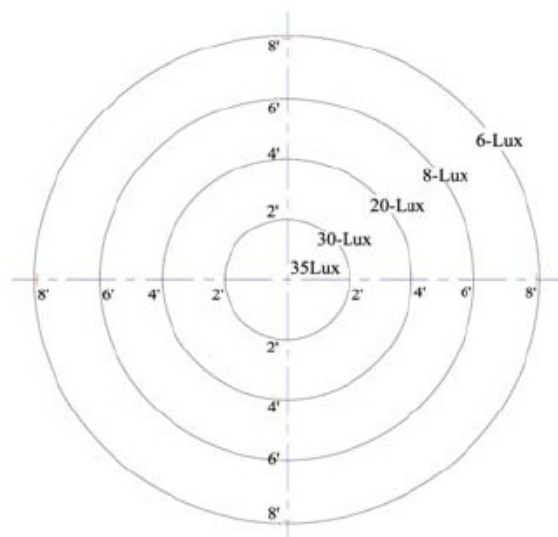
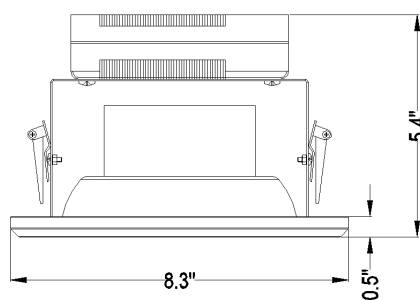

Figure 1 : Luminous Intensity Diagram



Test Height: 8-Foot  
Iso-Lux Graph

### POP



Surface Mount Light - Installed Condition

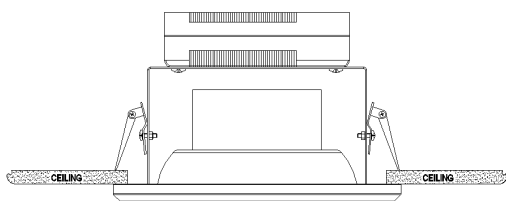

### Surface Mount

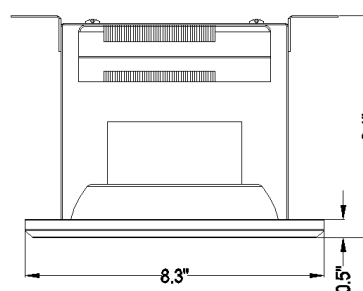

POP Mount Light - Installed Condition

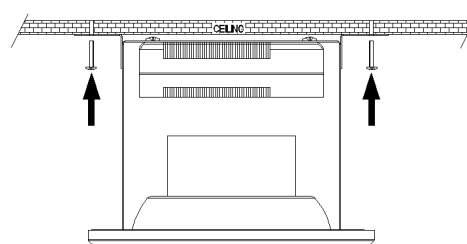

Model no. DL01001206

Note: The specifications are subject to change without prior notice.

Vignani Solutions Pvt. Ltd. 93/A, 4th B cross, 5th Block, Koramanagala Industrial Area, Bangalore 560095

Telephone +91 80 4200 4212 | Fax: +91 80 4200 4260 / email: info@cleanray.in / www.cleanray.in

All cleanray products, patent pending technologies and brandnames are intellectual properties of vignani solutions. all rights reserved.